

Juno System

SITE REQUIREMENTS GUIDE



For Research Use Only. Not for use in diagnostic procedures.

Information in this publication is subject to change without notice. It is Fluidigm policy to improve products as new techniques and components become available. Therefore, Fluidigm reserves the right to change specifications at any time. Every effort has been made to avoid errors in the text, diagrams, illustrations, figures, and screen captures. However, Fluidigm assumes no responsibility for any errors or omissions. In no event shall Fluidigm be liable for any damages in connection with or arising from the use of this publication.

Patent and Limited License Information

Fluidigm products are covered by issued and pending patents in the United States and other countries. Patent and limited license information is available at fluidigm.com/legalnotices.

Limited Use License to Perform Pre-amplification with Fluidigm IFCs

A license to use Thermo Fisher Scientific's patented pre-amplification method workflows involving a Fluidigm integrated fluidic circuit (IFC) can be obtained (i) with purchase of a Fluidigm IFC from Fluidigm Corporation or (ii) by a separate license from Thermo Fisher Scientific. For licensing information, contact outlicensing@lifetech.com.

Limited Digital PCR License

A license to use Thermo Fisher Scientific's patented digital PCR method in all fields other than in the Sequencing Field, the Mass Spectrometry Field, and the Prenatal Field in workflows involving a Fluidigm IFC can be obtained (i) with purchase of a Fluidigm IFC from Fluidigm Corporation or (ii) by a separate license from Thermo Fisher Scientific. For licensing information, contact outlicensing@lifetech.com.

Trademarks

Fluidigm, the Fluidigm logo, Juno, and SNP Type are trademarks or registered trademarks of Fluidigm Corporation in the United States and/or other countries. All other trademarks are the sole property of their respective owners.

For EU's WEEE directive information, go to fluidigm.com/compliance.

© 2017 Fluidigm Corporation. All rights reserved. 06/2017

For technical support visit fluidigm.com/support.

North America +1 650 266 6100 | Toll-free (US/CAN): 866 358 4354 | techsupport@fluidigm.com

Latin America +1 650 266 6100 | techsupportlatam@fluidigm.com

Europe/Middle East/Africa/Russia +44 1223 859941 | techsupporteurope@fluidigm.com

Japan +81 3 3662 2150 | techsupportjapan@fluidigm.com

China (excluding Hong Kong) +86 21 3255 8368 | techsupportchina@fluidigm.com

All other Asian countries/India/Australia +1 650 266 6100 | techsupportasia@fluidigm.com

Contents

About This Guide	4	Instrument Safety	21
Safety Alert Conventions	4	Electrical Safety	22
Safety Alerts for Chemicals	4	Chemical Safety	22
Safety Alerts for Instruments	5		
Safety Data Sheets	5		
Site Requirements	6		
Introduction	6		
Site Preparation Workflow	6		
Step 1: Review This Guide	6		
Step 2: Review Equipment Lists	7		
Equipment for Use with the Juno 96.96			
Genotyping IFC	7		
Equipment for Use with the Juno LP—192.24			
IFC and LP—48.48 IFC	8		
Optional Interface Plates	8		
Step 3: Meet Site Requirements	9		
Harmonized Standards	9		
Environmental Conditions	9		
Laboratory Bench Requirements	11		
Electrical Requirements	12		
(<i>Optional</i>) In-House Air Supply	15		
Step 4: Stock the Site	16		
Required Safety Equipment	16		
Step 5: Receive the System	17		
Delivery and System Inspection	17		
System Size and Weight Specifications	18		
Path Clearances	19		
Step 6: Place the System at the Site	19		
System Weight	19		
Installation	19		
Installation Time Estimate	20		
Appendix: Safety	21		
General Safety	21		

About This Guide

IMPORTANT Before using the system, read and understand the safety guidelines in this document. Failure to follow these guidelines may result in undesirable effects, injury to personnel, and/or damage to the system or to property.

For more information on instrument operation and safety, see the Juno System User Guide (PN 100-7070). For related documentation, go to fluidigm.com/documents.

Safety Alert Conventions



CAUTION ABBREVIATED SAFETY ALERTS. Hazard symbols and hazard types specified in procedures may be abbreviated in this document. For complete safety information, see the safety appendix on [page 21](#).

This guide uses specific conventions for presenting information that may require your attention. Refer to the following safety alert conventions.

Safety Alerts for Chemicals

Fluidigm follows the United Nations Globally Harmonized System of Classification and Labelling of Chemicals (GHS) for communicating chemical hazard information. GHS provides a common means of classifying chemical hazards and a standardized approach to chemical label elements and safety data sheets (SDSs). Key elements include:

- Pictograms that consist of a symbol on a white background within a red diamond-shaped frame. Refer to the individual SDS for the applicable pictograms and warnings pertaining to the chemicals being used.



- Signal words that alert the user to a potential hazard and indicate the severity level. The signal words used for chemical hazards under GHS:

DANGER Indicates more severe hazards.

WARNING Indicates less severe hazards.

Safety Alerts for Instruments

For hazards associated with instruments, this guide uses the following indicators:

- Pictograms that consist of a symbol on a white background within a black triangle-shaped frame.



- Signal words that alert the user to a potential hazard and indicate the severity level. The signal words used for instrument hazards:

DANGER Indicates an imminent hazard that will result in severe injury or death if not avoided.

WARNING Indicates a potentially hazardous situation that could result in serious injury or death.

CAUTION Indicates a potentially hazardous situation that could result in minor or moderate personal injury.

IMPORTANT Indicates information necessary for proper use of products or successful outcome of experiments.

Safety Data Sheets

Read and understand the SDSs before handling chemicals. To obtain SDSs for chemicals ordered from Fluidigm Corporation, either alone or as part of this system, go to fluidigm.com/sds and search for the SDS using either the product name or the part number.

Some chemicals referred to in this user guide may not have been provided with your system. Obtain the SDSs for chemicals provided by other manufacturers from those manufacturers.

Site Requirements

For more information on instrument operation and safety, see the Juno System User Guide (PN 100-7070). For related documentation, go to fluidigm.com/documents.

Introduction

Fluidigm technical support will schedule a time to install the Juno™ system at your site and train your staff to use the system. Before a Fluidigm service representative arrives to install the system, you need to choose and prepare your site according to the instructions in this document.

Notify your Fluidigm representative if special shipping arrangements are necessary at your site, or if you need assistance in placing the Juno system.

Site Preparation Workflow

Perform the following six steps to choose and prepare your site:

- 1 Review this guide.
- 2 Review required reagents and ancillary equipment lists.
- 3 Select a site for the Juno system that meets Fluidigm requirements.
- 4 Stock the site with the required safety equipment.
- 5 Receive the Juno system and perform a visual check of the crate and containers. If damage is apparent, contact Fluidigm technical support.
- 6 Place the crated and boxed components at their final destination.

Step 1: Review This Guide

Use this guide for information on all Juno system site requirements, including safety, environmental, electrical, and space requirements.

Step 2: Review Equipment Lists

NOTE For complete lists of reagents and consumables, see the Genotyping with Juno Getting Started Guide (PN 100-7074) and the Targeted DNA Sequencing Library Preparation with Juno Getting Started Guide (PN 101-0414).

Equipment for Use with the Juno 96.96 Genotyping IFC

✓

Required Equipment for TaqMan® Juno 96.96 Genotyping IFC	Company	Part Number
Juno system, with system software v3.1 or later. The system includes the instrument, software, MX Interface Plate, Interface Plate Loading Fixture, Cleaning Plate, and Barrier Tape Applicator and Adapter	Fluidigm	101-6455
For Juno 96.96 Genotyping IFC: SX Interface Plate	Fluidigm	100-6368
Fluidigm Data Collection software v4.2 or later	Fluidigm	—
Fluidigm SNP Genotyping Analysis software v4.2 or later	Fluidigm	—
Pipettes (P2, P10, P20, P200, P1000) and appropriate low-retention tips	Major laboratory supplier (MLS)	—
8-channel pipettes and appropriate low-retention tips	MLS	—
Microcentrifuge	MLS	—
Vortexer	MLS	—

✓

Suggested Equipment for the TaqMan Juno 96.96 Genotyping IFC	Company	Part Number
DNA hood and DNA-free hood	MLS	—

Equipment for Use with the Juno LP—192.24 IFC and LP—48.48 IFC

✓

Required Equipment for the Juno LP—192.24 IFC and LP—48.48 IFC	Company	Part Number
Juno system, with system software v3.5 or later. The system includes the instrument, software, MX Interface Plate, Interface Plate Loading Fixture, Cleaning Plate, and Barrier Tape Applicator and Adapter	Fluidigm	101-6455
For Juno LP—192.24 IFC: TX Interface Plate	Fluidigm	101-6117
DynaMag™-2 Magnet or equivalent	Thermo Fisher Scientific	12321D
Pipettes (P2, P10, P20, P200, P1000) and appropriate low-retention tips*	MLS	—
8-channel pipettes and appropriate low-retention tips	MLS	—
Microcentrifuge	MLS	—
Vortexer	MLS	—
Centrifuge with rotor to accommodate 96- and 384-well plates	MLS	—

* Rainin® pipettes recommended.

✓

Suggested Equipment for the Juno LP—192.24 IFC and LP—48.48 IFC	Company	Part Number
DNA hood and DNA-free hood	MLS	—
2100 Bioanalyzer®	Agilent	G2940CA
Qubit® 3.0 Fluorometer*	Thermo Fisher Scientific	Q33216

* Earlier versions of the fluorometer are acceptable.

Optional Interface Plates

✓

Component	Company	Part Number
HX Interface Plate Supports 96.96 Dynamic Array™ and Flex Six™ IFCs	Fluidigm	101-6116
RX Interface Plate Supports 192.24 Genotyping and Gene Expression IFCs.	Fluidigm	101-6114

Step 3: Meet Site Requirements

To operate Juno, your site should meet the following requirements:

- Harmonized standards
- Environmental conditions
- Laboratory bench requirements
- Electrical requirements
- (Optional) In-house air supply

Harmonized Standards

IMPORTANT The installation location **cannot** be designated Biosafety Level 3 (BSL-3) or Biosafety Level 4 (BSL-4). Fluidigm does not install, service, or repair Juno in areas designated BSL-3 or BSL-4.

Juno conforms with the provisions of the following harmonized standards:

- IEC/EN 61326-1
- IEC/EN 61326-2-1
- IEC/EN 61010-1
- IEC/EN 61010-2-010
- IEC/EN 61010-2-081
- UL Standard Number 61010-1 2nd Edition
- CAN/CSA-C22.2 No. 61010-1-04
- CAN/CSA-C22.2 No. 61010-2-010:4
- CAN/CSA-C22.2 No. 61010-2-081-04

Environmental Conditions

Altitude

Juno is for use in altitudes not exceeding 2,000 m (6,562 ft) above sea level. If your facility is located above this elevation, call technical support.

Humidity and Temperature

IMPORTANT

- Do not locate the system next to heat sources or cooling ducts, or in direct sunlight or extreme ambient lighting. Temperature extremes can cause system instability.
- Juno is for indoor use only.

Juno should be used in an environment that meets the requirements shown below:

Conditions	Requirements
Temperature	Ambient: 15 °C and 28 °C (59–82 °F)
Humidity	20%–80%, noncondensing
Pollution	Degree 2
Electrical Installation	Category II
Altitude	Up to 2,000 m (6,562 ft)

Pollution

Juno conforms to standard laboratory environments. Do not install the system where conductive pollutants are present.

Ventilation Requirements

Juno produces only hot-air exhaust, no fumes or vapors. The instrument has an exhaust grill exit on the back of the instrument. At least 10.2 cm (4 in) of clearance must be maintained at the exhaust grill exit.

The air intake is on the bottom of the instrument.

IMPORTANT Do not place paper or any object underneath the instrument.

Ensure your lab space is ventilated using non-recirculating air exchanges.

Laboratory Bench Requirements

IMPORTANT Weight: Your laboratory bench must support at least 91 kg (200 lb).

Provide a work surface that can accommodate Juno. The table and figure below show the dimensions and weight of the instrument:

Length	Width	Height	Weight
69.8 cm (27.5 in)	43.9 cm (17.3 in)	50.0 cm (19.7 in)	62 kg (137 lb)

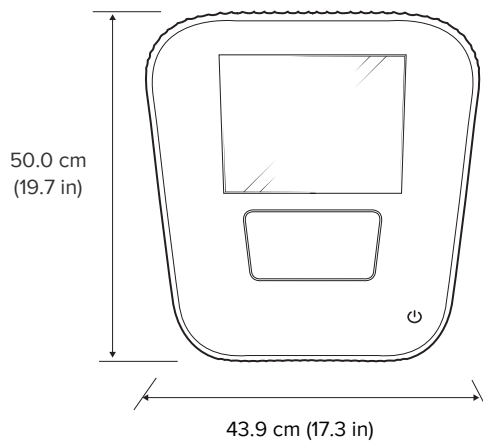
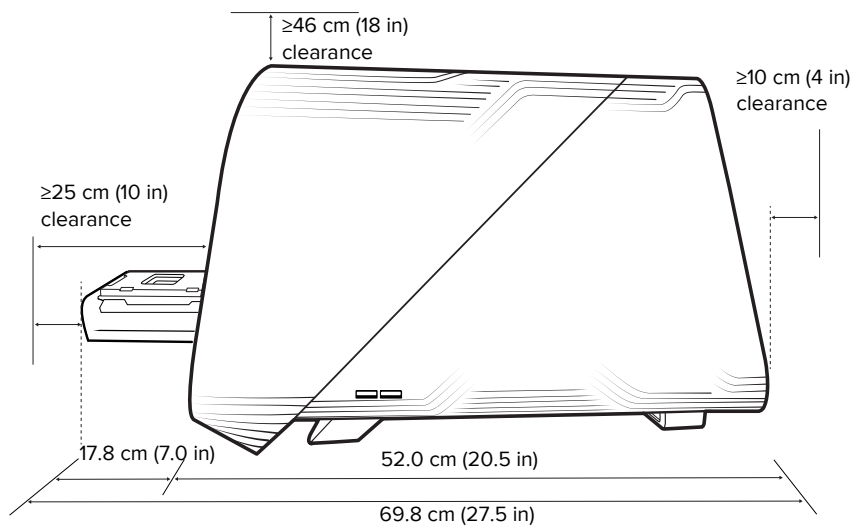

Juno is a desktop instrument. To accommodate one instrument, we recommend a bench top with minimum depth of 76 cm (30 in) and width of 48 cm (19 in). To allow adequate air circulation and maintenance, keep at least 10 cm (4 in) clearance behind, 25 cm (10 in) in front, and 46 cm (18 in) above the instrument. The bench must be able to support 200 lb.

IMPORTANT

- Do not place the system on a heated surface or directly above a source of heat.
- Position the system so the power cord can be easily disconnected.

Electrical Requirements

This section applies to Juno. For the electrical requirements of other Fluidigm equipment, see respective equipment documentation.

Electrical Installation

Category II

Juno Electrical Requirements

Juno requires one electrical power outlet. The system operates through 100–240 V AC power at 50/60 Hz (8.0 A):

Customer Location	Voltage (V AC)	Frequency (Hz)	Maximum Current (A)	Typical Average Power Consumption (W)
Japan	100 ±10%	50–60 ±1%	8.0	Idle: 40 Operating: 175
United States, Canada	115 ±10%	50–60 ±1%	8.0	Idle: 40 Operating: 175
Europe, Australia	230 ±10%	50–60 ±1%	3.7	Idle: 40 Operating: 175

Instrument Labeling

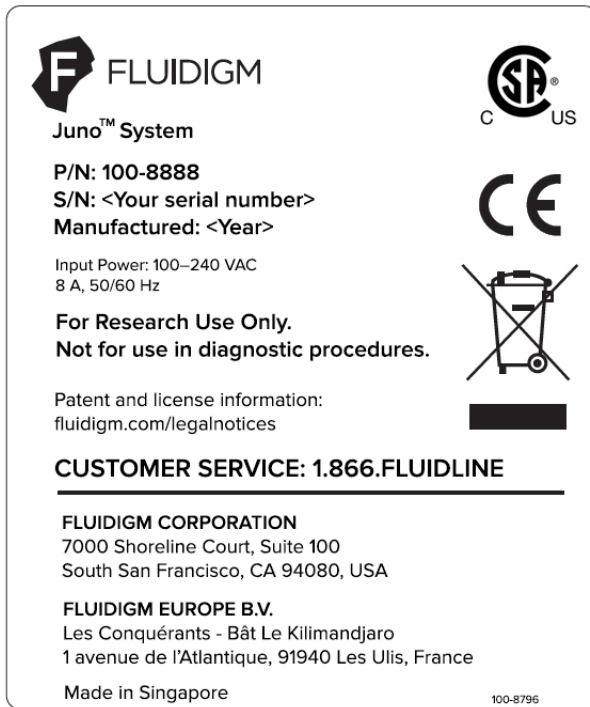

IMPORTANT Supply voltage fluctuation not to exceed $\pm 10\%$ of the normal value. If the voltage fluctuation exceeds normal value, see [Strong Recommendation for Uninterruptible Power Supply](#) on page 14.

Power Cord Requirements

Fluidigm provides a country-specific power cord.

Customer Location	Minimum Wire Gauge (AWG)	Maximum Length (m)	Instrument End Plug	Receptacle End Plug
Japan, United States, Canada	14	2	IEC C13	Country-specific
Europe, Australia	16	2	IEC C13	Country-specific

Receptacle Requirements

When connecting this instrument to a receptacle, check with your facilities manager to make sure the circuit will not be overloaded. If you are connecting multiple instruments to the same electrical receptacle or circuit, be sure the sum of all the instruments' maximum current draw is within the circuit's current limit. Receptacles must be grounded.



The instrument has a connection to protective earth through the power cord provided by Fluidigm. Ensure that the electrical receptacle provides an earth ground before connecting the power cord.

Use only power cords provided by Fluidigm or power cords that meet the minimum ratings of 250V/10A, 16AWG and a length not exceed 2 m (6 feet).

IMPORTANT Do not use extension cords.

Strong Recommendation for Uninterruptible Power Supply

Fluidigm strongly recommends that you protect your Juno system with an uninterruptible power supply (UPS). Fluctuating voltage can compromise your system's performance and the outcome of your experiment. We encourage a UPS for all installed instruments, but it is particularly critical for geographic regions that have electrical voltage fluctuations exceeding $\pm 10\%$ of normal range. The minimum requirements for the UPS to maintain power for one system are:

Conditions	Requirements
Output power capacity	300 W (400 VA)
Backup time (run time)	2 hr
Power draw (load)	175 W

A recommended vendor is Franek Technologies (franek.com).

Disconnecting Power

In case of emergency, you must be able to immediately disconnect the main power supply to the instrument by removing the plug from the outlet.

(Optional) In-House Air Supply

Juno has an internal compressor to generate compressed air and draws in ambient air by default. The instrument can draw in-house air, and it must be clean dry air (CDA). To use in-house compressed air, attach 1/4-inch outside diameter tubing into the air inlet on the back of the system. The allowable pressure input is listed on the back of the instrument.

For detailed instructions on enabling use of in-house air, see the Juno System User Guide (PN 100-7070).

Step 4: Stock the Site

IMPORTANT Safety personnel at your company must ensure that:

- Safety policies to protect laboratory personnel from potential harm are established and are followed by personnel.
- All necessary safety devices and equipment are in the laboratory or in close proximity.

Required Safety Equipment

Fluidigm expects your laboratory to have safety policies in place to protect laboratory personnel from potential harm. We expect that appropriate safety practices are followed at all times.

Safety equipment that must be at the installation location includes:

- Adequate ventilation, including vent line/fume hood, if applicable
- Safety shower
- Eyewash station
- Biohazard waste container, if applicable
- Applicable SDSs
- Protection from potentially infectious biological material, hazardous chemicals, and radiation that may be present in the area where the Fluidigm service representative will be working
- Spill cleanup equipment
- First-aid equipment
- Eye and hand protection
- Fire extinguisher
 - You are responsible for providing an appropriate fire extinguisher for use on or near Juno.
 - The fire extinguishers must be appropriate for use on chemical and electrical fires and be approved by your local fire marshal or other authority having jurisdiction in your area.

Step 5: Receive the System

Because Juno weighs approximately 62 kg/137 lb (82 kg/180 lb crated), consider where it is going to be delivered and how to get it to and into your laboratory.

IMPORTANT Do not tip Juno on end. Tipping damages the instrument hardware and electronics.

Delivery and System Inspection

For new Juno installations, you can anticipate receiving:

- Juno system, crated
- Instrument accessories, boxed

Use this checklist to perform a check of all delivered components:

- Check the packing list against the original order.
- Check all boxes and crates for damage.
- Note any damage and report it to the Fluidigm service representative.
- Locate the reagent kit (if ordered) and unpack immediately.
- Store each component at the appropriate temperature according to the instructions.

System Size and Weight Specifications



WARNING PHYSICAL INJURY HAZARD. Do not attempt to lift or move this instrument and/or crates without the use of appropriate moving/lifting equipment. The crated Juno system weighs 82 kg (180 lb).



Specifications	Juno system
Packaged	
Weight	82 kg (180 lb)
Dimensions	98.0 cm L x 66.5 cm W x 82.6 cm H (38.6 in L x 26.2 in W x 32.5 in H)
Unpackaged	
Weight	62 kg (137 lb)
Dimensions	69.8 cm L x 43.9 cm W x 50.0 cm H (27.5 in L x 17.3 in W x 19.7 in H)

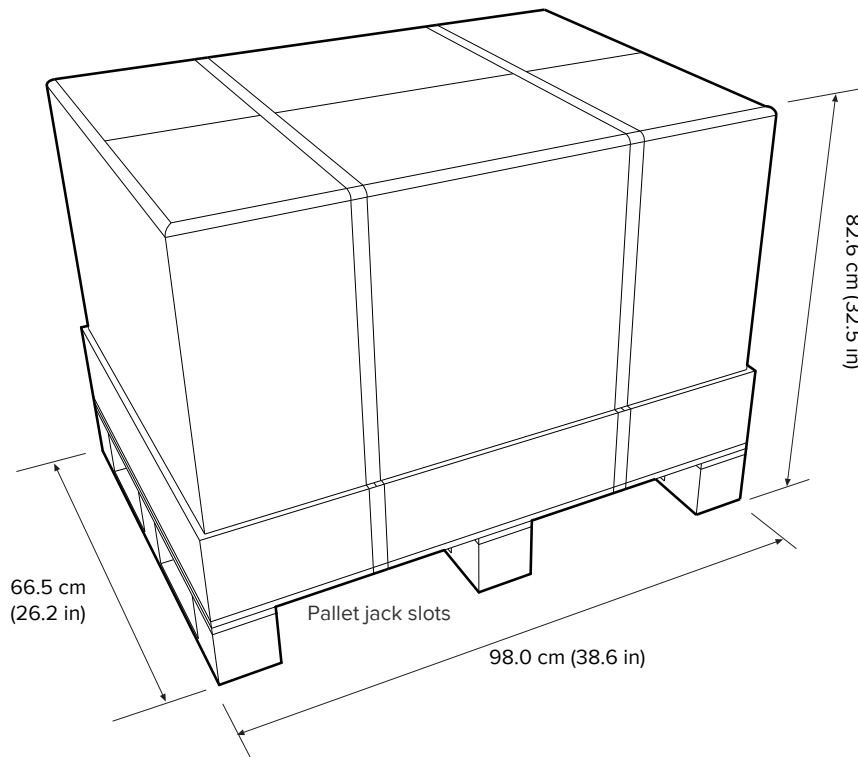

Figure 1. Juno system (crated)

Path Clearances

IMPORTANT Establish a clear path from the loading dock to the laboratory bench. The path must accommodate the dimensions of the crate.

Make sure the path to the installation site has the following minimum clearances:

Height	91 cm (36 in)
Width	102 cm (40 in)

Step 6: Place the System at the Site

Remove all unnecessary materials from the proposed installation site prior to the arrival of the Fluidigm field service engineer.

Have the crated Juno system at its permanent location prior to the arrival of a field service engineer. Wait for the engineer to arrive before unpacking the crate.

System Weight



WARNING PHYSICAL INJURY HAZARD. Do not attempt to lift or move any boxed or crated items unless you use proper lifting techniques. The crated Juno system weighs 82 kg (180 lb).



If you choose to lift or move Juno after it has been installed, do not attempt to do so without the assistance of others. Use appropriate moving equipment and proper lifting techniques to minimize the chance of physical injury.

Installation

Before the installation date, make sure you have done the following:

- Removed all unnecessary materials from the proposed final installation site
- Received the Juno system and performed a visual check of the crate and containers
- Moved the crated and boxed equipment from the receiving location to the installation area

Contact your Fluidigm representative if you require assistance with any of these steps.

Installation Time Estimate

Installation of the Juno system is estimated to take one day. Site issues and other factors may delay or extend the installation time.

Appendix: Safety

General Safety

In addition to your site-specific safety requirements, Fluidigm recommends the following general safety guidelines in all laboratory and manufacturing areas:

- Use personal protective equipment (PPE): safety glasses, fully enclosed shoes, lab coats, and gloves.
- Know the locations of all safety equipment (fire extinguishers, spill kits, eyewashes/showers, first-aid kits, safety data sheets, etc.), emergency exit locations, and emergency/injury reporting procedures.
- Do not eat, drink, or smoke in lab areas.
- Maintain clean work areas.
- Wash hands before leaving the lab.

Instrument Safety



WARNING Do not modify this device. Unauthorized modifications may create a safety hazard.



CAUTION HOT SURFACE The Juno thermal cycler chuck gets hot and can burn your skin. Use caution when working near the chuck.



CAUTION PINCH HAZARD. The Juno door and tray can pinch your hand. Make sure your fingers, hand, and shirtsleeves are clear of the door and tray when loading or ejecting an integrated fluidic circuit (IFC).



WARNING BIOHAZARD. If you are putting biohazardous material on the instrument, use appropriate personal protective equipment and adhere to *Biosafety in Microbiological and Biomedical Laboratories* (BMBL) from the Centers for Disease Control and Prevention and to your lab's safety protocol to limit biohazard risks. If biohazardous materials are used, properly label the equipment as a biohazard. For more information, see the BMBL guidelines at: [cdc.gov/biosafety/publications/index.htm](https://www.cdc.gov/biosafety/publications/index.htm).

Electrical Safety



WARNING ELECTRICAL HAZARD. Electrical shock can result if the Juno instrument is operated without its protective covers.



WARNING ELECTRICAL HAZARD. Plug the system into a properly grounded receptacle with adequate current capacity.

Chemical Safety

Read and comprehend all safety data sheets (SDSs) by chemical manufacturers before you use, store, or handle any chemicals or hazardous materials.

Wear personal protective equipment (gloves, safety glasses, fully enclosed shoes, lab coats) when handling chemicals.

Do not inhale fumes from chemicals. Use adequate ventilation, and return caps to bottles immediately after use.

Check regularly for chemical spills or leaks. Follow SDS recommendations for cleaning up spills or leaks.



For technical support visit fluidigm.com/support